

Motorbase Type MB 70

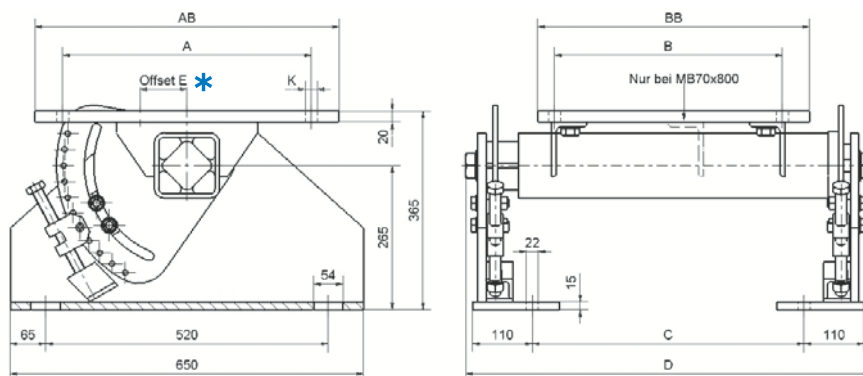

| Art. No. | Type | Motor Frame Size | P [kW] | | | A | AB | B | BB | C | D | E | K | Weight [kg] |
|------------|--------------------|------------------|------------------------|------------------------|------------------------|-----|-----|-----|-----|-----|-----|----|----|-------------|
| | | | 3000 min ⁻¹ | 1500 min ⁻¹ | 1000 min ⁻¹ | | | | | | | | | |
| 02 200 704 | MB 70 × 400 | 250M | 55 | 55 | 37 | 406 | 510 | 349 | 410 | 350 | 595 | 50 | 22 | 151 |
| 02 200 705 | MB 70 × 550 | 280S | 75 | 75 | 45 | 457 | 560 | 368 | 500 | 500 | 745 | 50 | 22 | 173 |
| | | 280M | 90 | 90 | 55 | 457 | 560 | 419 | 500 | 500 | 745 | 50 | 22 | |
| 02 200 706 | MB 70 × 650 | 315S | 110 | 110 | 75 | 508 | 630 | 406 | 570 | 600 | 845 | 70 | 26 | 192 |
| 02 200 707 | MB 70 × 800 | 315M | 132–160 | 132–160 | 90/110 | 508 | 630 | 457 | 750 | 723 | 968 | 70 | 28 | 222 |
| | | 315L | 160–200 | 160–200 | 110–160 | 508 | 630 | 508 | 750 | 723 | 968 | 70 | 28 | |

Details regarding special designs, see pages 106/107.

* All ROSTA-Motorbases MB 70 will be supplied with motor plate installed in **“centered”** configuration on top of the element axis. According to the final positioning of the base, the operating angle of the belts and the required tensioning travel, the motor plate can be altered in **“off-set”** position. Relevant threaded fixation holes are existent in plate.

For possibly required additional tensioning travel of the motor plate, the adjusting block of the pretensioning device can be set in one of the eleven hole positions of the friction plate (3).

- 1 Motor plate
- 2 Side supports
- 3 Pretensioning devices = 2 devices
- 4 Rubber suspension element with axial-guide bearing

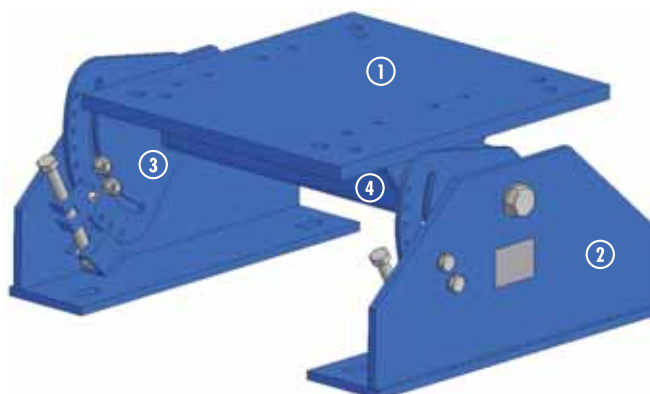

Mounting instructions for MB 70

1 Ascertainment of the ideal motorbase position

- █ longest tensioning travel, ideal position of the MB
- █ sufficient travel of the MB
- █ in this position, insufficient travel is given (contact **ROSTA**)

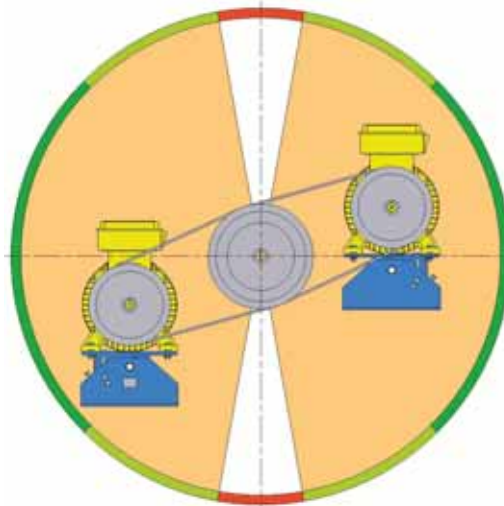

2 Axial-guide bearing *must* be on pulley side to avoid axial misalignment

If motor position has to be changed due to specific transmission configuration, turn element 180° around between the side-supports. **Axial-guide bearing shall never be on fan-side of the motor!** (2 × M30)

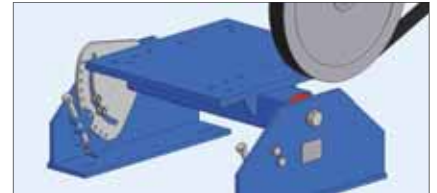

3 Support fixations

4 oblong holes 22×54 mm

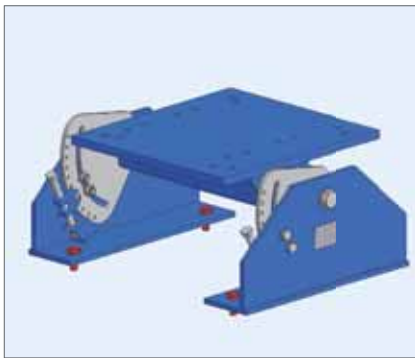

4 Alignment of pulleys and motor fixation

4 screws according relevant motor size

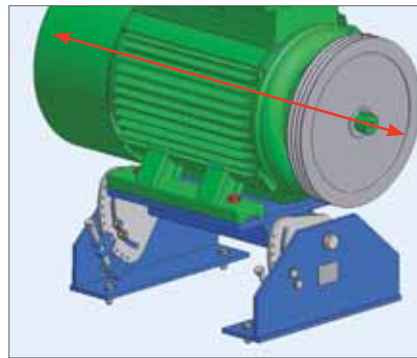

5 Loosen of the center screws (element axis) and of the screws on friction plates

M30 and M16

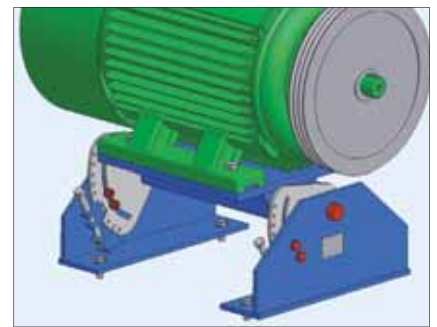

6 Insert and tension the belts, control belt test force

Tensioning of the belts according to belt suppliers recommended test force (table on page 97).

Adjust tension with screw M20×1.5

Readjustment of the pretensioning device to required tension travel

1. tighten shaft- and fixing screws (friction plates)
2. loosen M10 hex-screw of block and select new position, assure new position of block again
3. loosen the shaft and fixing screws again
4. continue the tensioning with screw M 20×1,5

7 Tighten of the center and fixing screws (friction plates), start of operation

M30 (locking torque 1400 Nm),
M16 (locking torque 210 Nm)

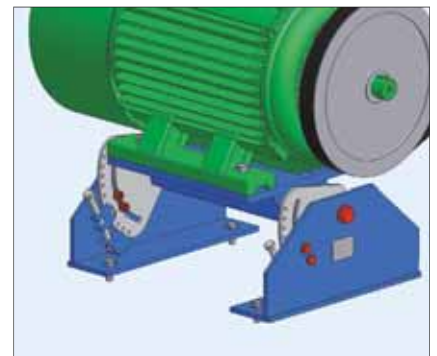
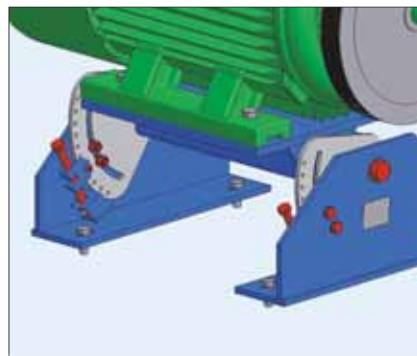
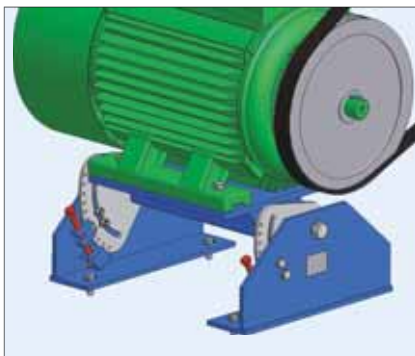

Retension:

Generally retensioning is not necessary, however, we recommend to control the belt tension after a few days of operation (after "running-in" of the belts).